

Technical Data

Hydraulic cable excavator HS 872 HD Litronic

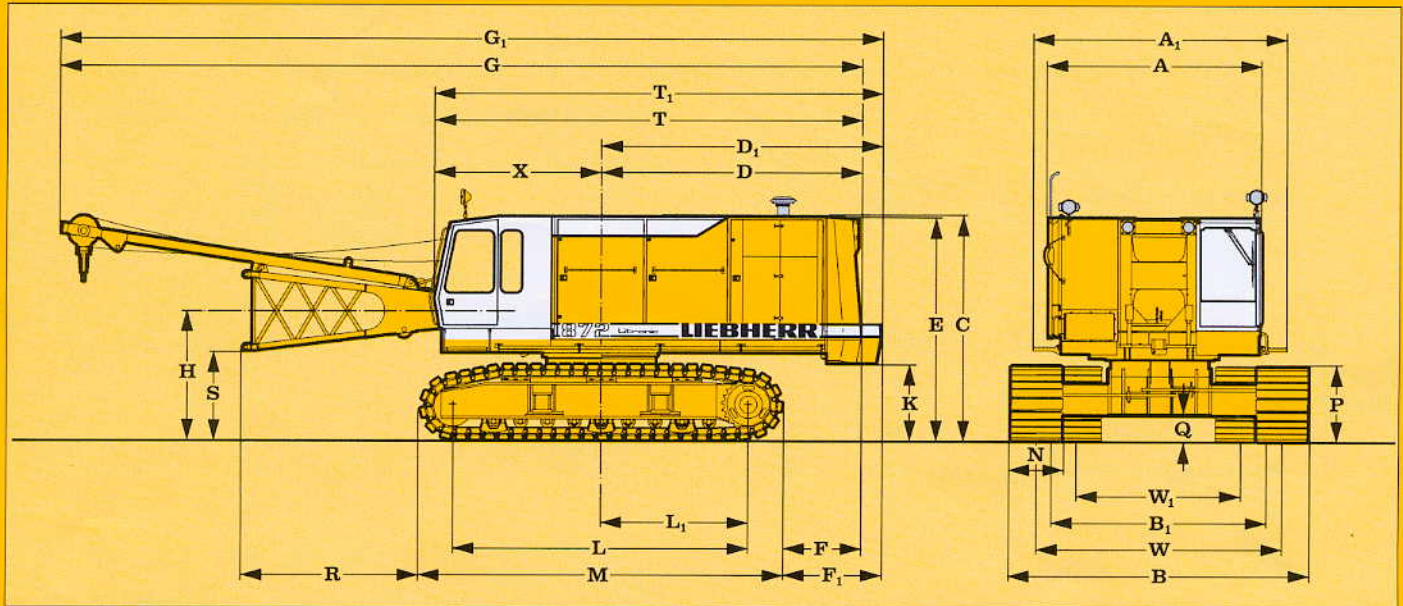

Basic machine



Dimensions

	mm				
A	Width of superstructure	3300/3480	R	Distance of horizontal boom foot over crawler	2243
A ₁	Width of superstructure with walk way	4040	S	Ground clearance of horizontal boom foot	1370
C	Clearance height of basic machine	3607	T	Length of basic machine	8337
D	Tail reach	5100	T ₁	Length of basic machine with add. counterweight of 4.5 mt	8697
	Tail swing radius	5150	X	Distance from center of rotation to end of cab	2625
D ₁	Tail reach with add. counterweight of 4.5 mt	5460			
	Tail swing radius with add. counterweight of 4.5 mt	5510	N	Width of track shoes	700 800 900 1000
E	Height over counterweight	3516	W ₁	Track width retracted	2980 2980 2980 2980
			W	Track width extended	3900 3900 3900 3900
F	Distance between rear end of crawler and outside of counterweight	1880	B ₁	Crawler width retracted	4000 4000 4000 4000
F ₁	Distance between rear end of crawler and outside of add. counterweight	2240	B	Crawler width extended	4600 4700 4800 4900
G	Overall length of superstructure with lowered A-frame	13780	Operating weight and ground pressure		
G ₁	Overall length of superstructure with lowered A-frame and add. counterweight	14140	The operating weight includes the basic machine with B8 crawler tracks, 2 main winches and 11 m HD-boom, consisting of A-frame, boom foot (4 m), boom head section (6.4 m), boom head (0.6 m) and 19.6 mt basic counterweight + 4.5 mt add. counterweight.		
H	Ground clearance of boom foot pivot	2090	with 700 mm flat track shoes: 94.1 mt - 1.15 kg/cm ²		
K	Clearance under superstructure to ground level	1260	with 800 mm flat track shoes: 95.1 mt - 1.02 kg/cm ²		
L	Wheel base (center idler to center tumbler)	5312	with 900 mm flat track shoes: 96.1 mt - 0.91 kg/cm ²		
L ₁	Distance from center of rotation to center of tumbler	2656	with 1000 mm flat track shoes: 97.1 mt - 0.83 kg/cm ²		
M	Length of crawlers	6444	with 700 mm 3-web shoes: 92.2 mt - 1.18 kg/cm ²		
P	Height of crawlers	1278	with 800 mm 3-web shoes: 93.0 mt - 1.04 kg/cm ²		
Q	Ground clearance of crawler	523	with 900 mm 3-web shoes: 93.8 mt - 0.94 kg/cm ²		
			with 1000 mm 3-web shoes: 94.6 mt - 0.85 kg/cm ²		

LIEBHERR

The Better Machine.

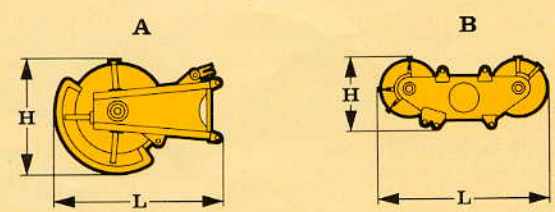
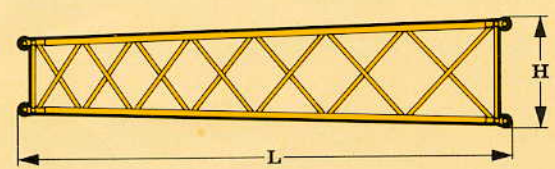
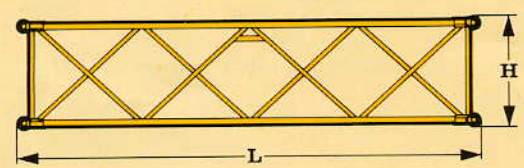
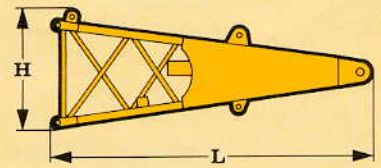
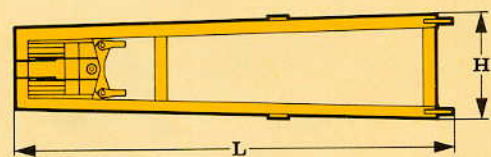
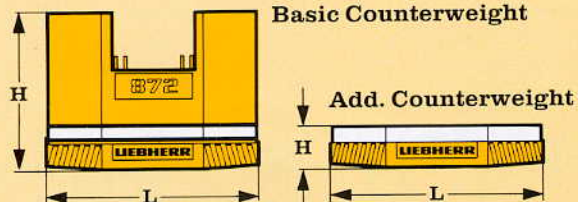
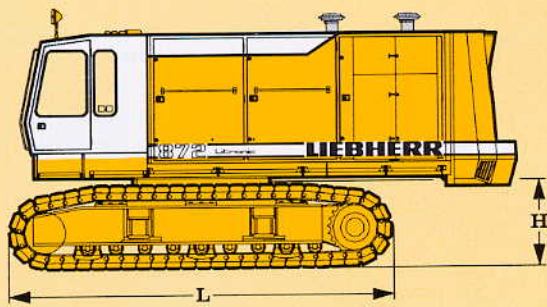

Basic machine

with V-12 motor, HD-undercarriage and 19.6 mt counterweight, winches 2 x 25 mt

Shoes	mm	700	800	900	1000
Weight	mt	81.9	82.7	83.5	84.3

Crawler retracted

Shoes	mm	700	800	900	1000
Width	mm	4000	4000	4000	4000
Weight	kgs	29600	30400	31200	32000
L = Length	mm	6444			
H = Height	mm	1382			

Counterweight Basic Additional

Width	mm	720	690
Weight	kgs	19600	4500
L = Length	mm	3200	3200
H = Height	mm	2200	585

A-frame

Width	mm	1250
Weight	kgs	1580
L = Length	mm	5800
H = Height	mm	1420

Boom foot

Width	mm	1485
Weight	kgs	1460
L = Length	mm	4200
H = Height	mm	1550

Tubular boom extensions

		3 m	6 m
Width	mm	1440	1440
Weight	kgs	650	1010
L = Length	mm	3130	6130
H = Height	mm	1450	1450

HD Boom Head Section 6.4 m

Width	mm	1420
Weight	kgs	1080
L = Length	mm	6530
H = Height	mm	1475

Boom head

		A	B
Width	mm	776	1060
Weight	kgs	1670	1730
L = Length	mm	2665	2820
H = Height	mm	1805	1170

Transport dimensions and weights



Engine

Mercedes-Benz, watercooled V-8 diesel, turbocharged with intercooler. Power rating according DIN 6271: Model OM 442 LA with 297 kW (404 HP) or Model OM 444 LA with 448 kW (609 HP) at 1900 RPM. Fuel tank: 920 l continuous fuel consumption indication with emergency tank level indication at approx. 40 l.



Hydraulic System

Four main pumps are driven by a distributor gear box. The axial piston displacement pumps work in a closed circuit supplying oil only when needed. A low loss pressure cut-off takes care of the pumps and saves energy. Winch 1 and 2: Axial piston displacement pumps (swash plate design) 565 l/min. each. Slewing gear: Axial piston displacement pump (swash plate design) 203 l/min. Boom hoist: Axial piston displacement pump (swash plate design) 203 l/min. Max. working pressure: 340 bar Hydraulic oil tank: 500 l capacity. Optional: Possibility of re-direction boom pump flow to the slewing gear for higher speed. Extended hydraulic system to drive external equipment with hydrostatic power. Oil tank of 1200 l.



Winches 1 and 2

Winch options:	16 mt	20 mt	25 mt
Line pull (nominal load):	160 kN	200 kN	250 kN
Rope diameter:	26 mm	30 mm	34 mm
Rope drum diameter:	550 mm	640 mm	750 mm
Line speed 1st layer m/min.	0 - 93	0 - 74	0 - 62
Line speed fast gear m/min.		0 - 124	0 - 115

Planetary gearbox in oil bath. Load support by hydraulic system. Additional security through spring loaded multi disc brake (parking brake). In the freefall mode the clutch and brake function is realized by a separate ample dimensioned multi disc working brake. The hoist and drag winches use variable oil motors controlled by high pressure. This allows the complete utilisation of the installed motorpower with partial loads through speed adaption. In clamshell operation the oilmotors distribute the load on both winches and compensate speed when working in different cable layers. Optional: Variable 2-speed crawler drive motor. Temperature of oilmotors is constantly monitored. Optional: Auxiliary winch: 50 kN (5 mt) Crane winch: 160 kN (16 mt) - with multi-disc brake but without free fall device.



Swing Drive

Single row ball bearing with external toothing for lower tooth flank pressure. Fixed axial piston oil motor, planetary gearbox, spring loaded and hydraulically released multi disc brake, swing gear pinion. A precision swing gear allows variable speed control within 3 selectable speed ranges, swing speed 0 - 3.3 RPM; freewheel moment control of superstructure, therefore almost wearless. Moment force sustained by diesel engine.



Boom Hoist Drive

Twin drum with internally located planetary gearbox, axial piston oil motor, hydraulically released spring-loaded multi-disc brake. Max. line pull 2 x 70 kN (2 x 7 mt). Rope diameter 20 mm, line speed 0 - 27 m/min. Optional: Second swing gear, 2 speed selection.



Crawler

Propulsion through axial piston motor, hydraulically released spring-loaded multi-disc brake, planetary gear box, maintenance free crawler tracks, hydraulic-type chain tensioning device, flat track- or 3-web shoes. Driving speed 0 - 2.4 km/h. Optional: 2 speed oil motor for higher driving speeds.



Control System

Electric control impulses are prepared for hydraulic control in the programmable electronic part. The specially treated electronic components are designed for the hard environment for this type of machine. Master control lever (cross movement) for swing and boom movements, double T-lever for winch 1 and 2 or crawlers. Electro-hydraulic continuous proportioning control for work and displacement motions. Dragline only: Interlock control. Cinematic reversal energy for drag winch is transmitted to the hoist winch, when lifting full bucket to dump, thus saving brakes and energy. Please ask for details of our patented automatic free fall device.



Equipment

- Tubular HD boom up to 50 m.
- Multi sheave HD boom head or dragline boom head.
- Dragline, clamshell or crane equipment.
- Attachments are possible for piling, drilling, oscillating equipment etc.
- For dragline operation a fairlead is attached to the boom foot to minimize cable wear out.

Technical Description

19.6 mt counterweight + 4.5 mt add. counterweight

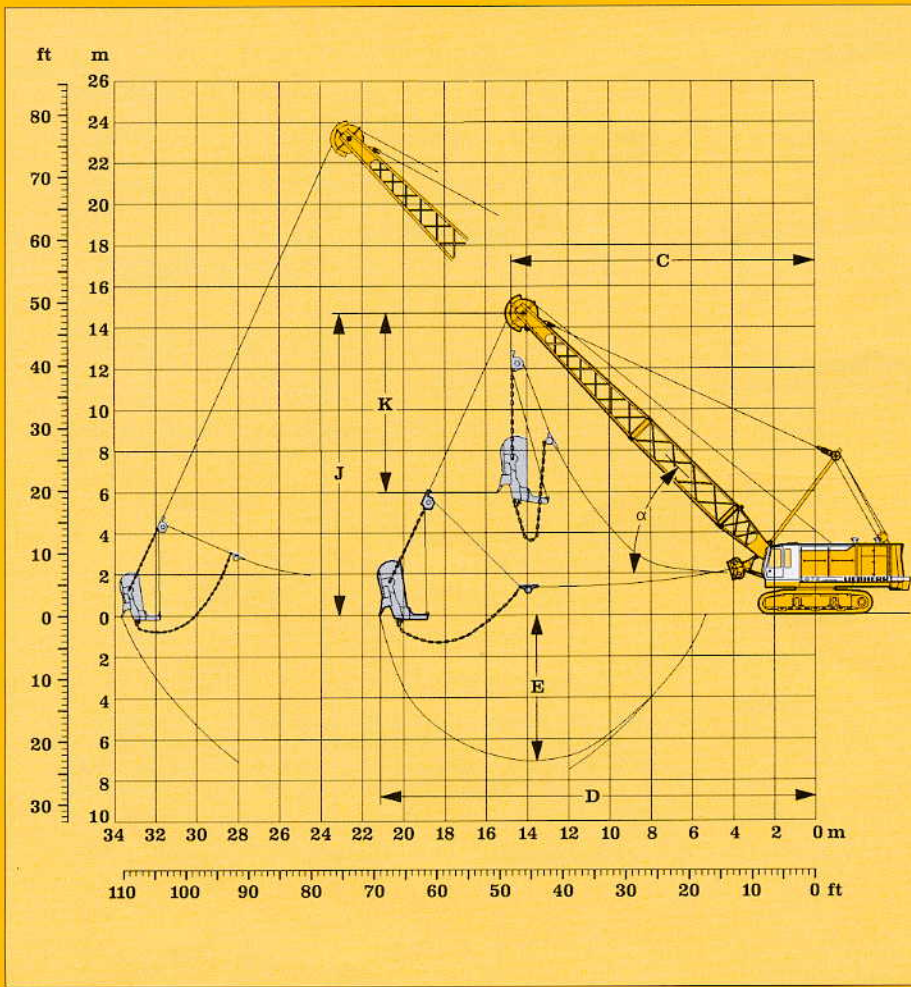

Scope of delivery:

- Basic machine with corresponding track shoes
- Second swing gear with freewheel control
- Add. counterweight of 4.5 mt
- A-frame
- Boom foot
- Boom extension 3 m, tubular steel
- Boom extension 6 m, tubular steel
- Boom head extension 6.4 m
- Boom head
- Stay ropes according to boom length
- Main winches according to specification
- Corresponding fair lead
- Corresponding cables
- Dragline bucket

Digging diagram:

- C = Radius / dumping radius
- D = Max. digging radius = approx. $C + 1/3$ to $1/2$ of $J - K$
- E = Digging depth = approx. 40 % al 50 % of C
- J = Height of boom head sheave center above ground level
- K = Length of dragline bucket (depending on type and capacity of bucket)

Boom length: 15 m to 30 m			Counterweight: 24.1 mt															
α°	15 m			18 m			21 m			24 m			27 m			30 m		
	C	J	t	C	J	t	C	J	t	C	J	t	C	J	t	C	J	t
	m	m	t	m	m	t	m	m	t	m	m	t	m	m	t	m	m	t
45	12.6	12.7	20.4	14.7	14.8	16.3	16.9	16.9	13.1	19.0	19.0	11.2	21.1	21.2	9.5	23.2	23.3	8.1
40	13.5	11.7	18.7	15.8	13.6	14.6	18.1	15.6	12.0	20.4	17.6	10.2	22.7	19.4	8.6	25.0	21.3	7.2
35	14.3	10.7	17.3	16.8	12.4	13.3	19.2	14.1	11.2	21.7	15.8	9.4	24.1	17.5	7.8	26.6	19.3	6.5
30	15.0	9.6	16.0	17.6	11.1	12.4	20.2	12.6	10.2	22.8	14.1	8.5	25.4	15.6	7.0	28.0	17.1	5.8
25	15.6	8.4	15.0	18.3	9.7	11.8	21.0	10.9	9.2	23.8	12.2	7.6	26.5	13.5	6.3	29.2	14.7	5.2
Content of dragline bucket.																		
cu.yd.	6			5 1/2			5			4			3 1/2			3		
m ³	4.6			4.2			3.8			3			2.7			2.3		

Max. lifting capacities in metric tons do not exceed 75% of tipping load.

Dragline equipment

19.6 mt counterweight + 4.5 mt add. counterweight

Scope of delivery:

- Basic machine with corresponding track shoes
- Second swing gear with free-wheel control
- Add. counterweight of 4.5 mt
- A-frame
- Boom foot
- Boom extension 3 m, tubular steel
- Boom extension 6 m, tubular steel
- Boom head extension 6.4 m
- Boom head
- Stay ropes according to boom length
- Main winches according to specification
- Corresponding cables
- Clamshell
- 4-rope clamshell on request
- Load moment limiter

Digging diagram:

- C = Radius / dumping radius
 J = Height of boom head sheave center above ground level
 K = Length of clamshell (depending on type and capacity of bucket)

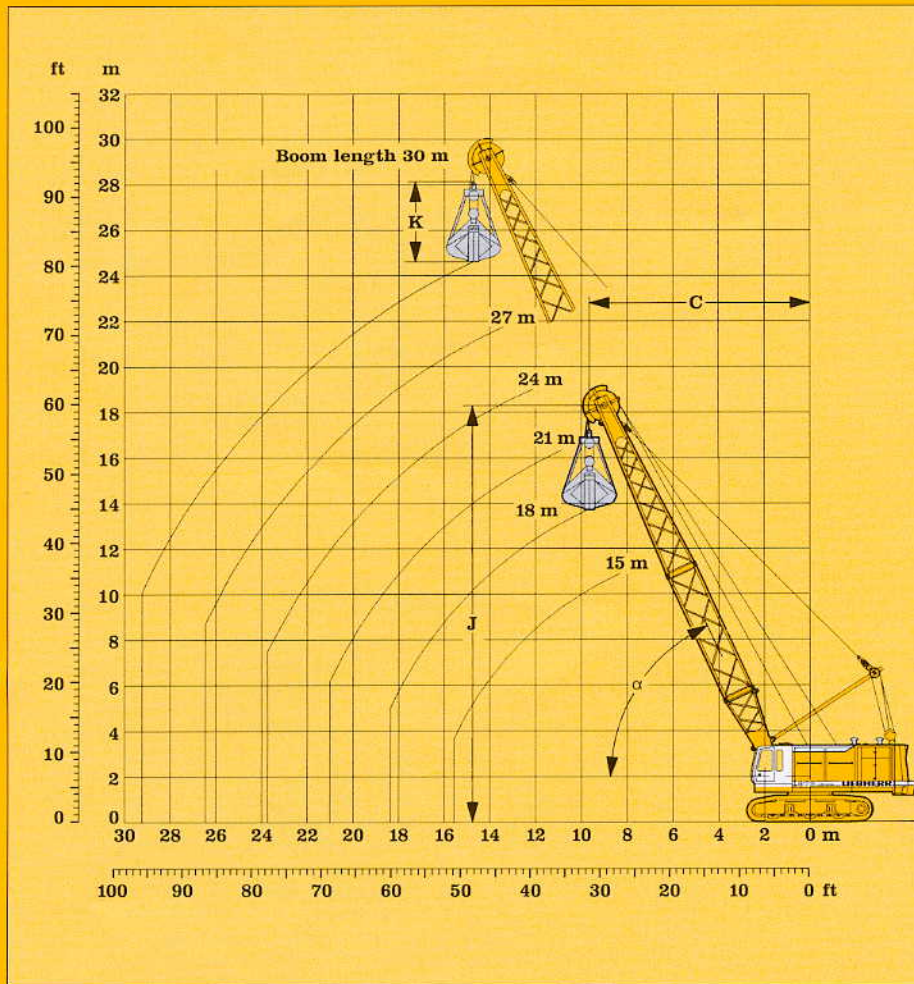

Boom length: 15 m to 30 m			Total Counterweight: 24.1 mt															
α°	15 m			18 m			21 m			24 m			27 m			30 m		
	C	J	t	C	J	t	C	J	t	C	J	t	C	J	t	C	J	t
	m	m	t	m	m	t	m	m	t	m	m	t	m	m	t	m	m	t
65	8.4	15.6	28.0	9.6	18.4	23.5	10.9	21.1	20.3	12.2	23.8	17.6	13.4	26.5	15.3	14.7	29.2	13.4
60	9.5	15.0	26.5	11.0	17.6	21.4	12.5	20.2	18.2	14.0	22.8	15.4	15.5	25.4	13.2	17.0	28.0	11.4
55	10.6	14.3	23.0	12.4	16.8	18.7	14.1	19.3	15.5	15.8	21.7	13.1	17.5	24.2	11.2	19.2	26.6	9.6
50	11.7	13.5	20.3	13.6	15.8	16.4	15.5	18.1	13.6	17.4	20.4	11.4	19.4	22.7	9.6	21.3	25.0	8.2
45	12.6	12.7	18.2	14.7	14.8	14.7	16.9	16.9	12.1	19.0	19.0	10.1	21.1	21.2	8.5	23.2	23.3	7.2
40	13.5	11.7	16.6	15.8	13.6	13.3	18.1	15.6	10.9	20.4	17.5	9.1	22.7	19.4	7.6	25.0	21.3	6.4
35	14.3	10.7	15.3	16.8	12.4	12.3	19.2	14.1	10.1	21.7	15.8	8.3	24.1	17.5	6.9	26.6	19.3	5.7
30	15.0	9.6	14.4	17.6	11.1	11.5	20.2	12.6	9.4	22.8	14.1	7.7	25.4	15.6	6.4	28.0	17.1	5.3
25	15.6	8.4	13.5	18.3	9.7	10.8	21.0	10.9	8.8	23.8	12.2	7.2	26.5	13.5	5.9	29.2	14.7	4.9

Max. lifting capacities in metric tons do not exceed 66.7 % of the tipping load.

Max. lifting capacities: 18.5 mt with 250 kN winch (25 mt)
 14.5 mt with 200 kN winch (20 mt)
 11.0 mt with 160 kN winch (16 mt)

Clamshell equipment

19.6 mt counterweight + 4.5 mt add. counterweight

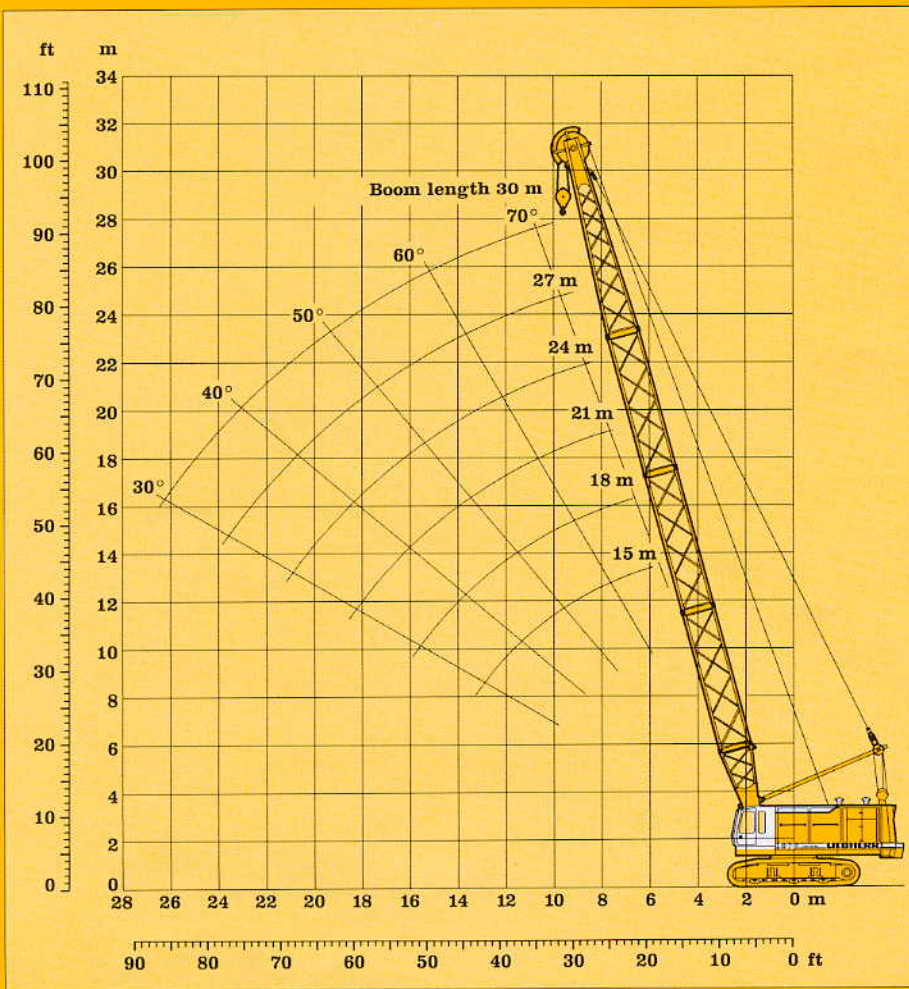

Scope of delivery:

- Basic machine with corresponding track shoes
- Add. counterweight of 4.5 mt
- A-frame
- Boom foot
- Boom extension 3 m, tubular steel
- Boom extension 6 m, tubular steel
- Boom head extension 6.4 m.
- Boom head
- Stay ropes according to boom length
- Main winches according to specification
- Corresponding hook block
- Load moment limiter

Remarks:

1. The lifting capacities with dragline boom head are valid for wide track.
2. The lifting capacities stated do not exceed 75 % of the tipping load.
3. The lifting capacities are indicated in metric tons with unlimited swing (360 degrees).
4. The weight of the lifting device must be deducted to arrive at the net load lifting capacity.
5. Working radii are measured from center of swing.
6. Machine standing on firm, level and uniform ground.

Radius m	Boom length m					
	15	18	21	24	27	30
5	40.4					
5.5	39.3	35.4				
6	38.3	34.6	31.3			
6.5	37.4	33.7	30.6	28.0		
7	36.4	33.0	30.0	27.4	23.7	
7.5	35.5	32.2	29.3	26.8	23.2	21.4
8	34.7	31.5	28.7	24.7	22.8	21.0
9	32.4	30.0	27.5	23.8	21.9	20.2
10	28.0	27.9	26.3	22.8	21.1	19.5
11	24.6	24.5	23.8	22.0	20.3	18.8
12	21.9	21.8	21.6	21.1	19.5	18.1
13	19.7	19.6	19.4	19.2	18.8	17.4
14	17.8	17.7	17.5	17.3	17.1	16.8
15	16.2	16.1	16.0	15.8	15.6	15.4
16		14.8	14.6	14.4	14.2	14.0
17		13.6	13.4	13.3	13.1	12.9
18		12.6	12.4	12.2	12.0	11.8
19			11.5	11.3	11.1	10.9
20			10.7	10.5	10.3	10.1
22				9.2	9.0	8.8
24				8.0	7.9	7.7
26					6.9	6.7
28						5.9
30						5.2

Lifting capacity with dragline boom head

19.6 mt counterweight

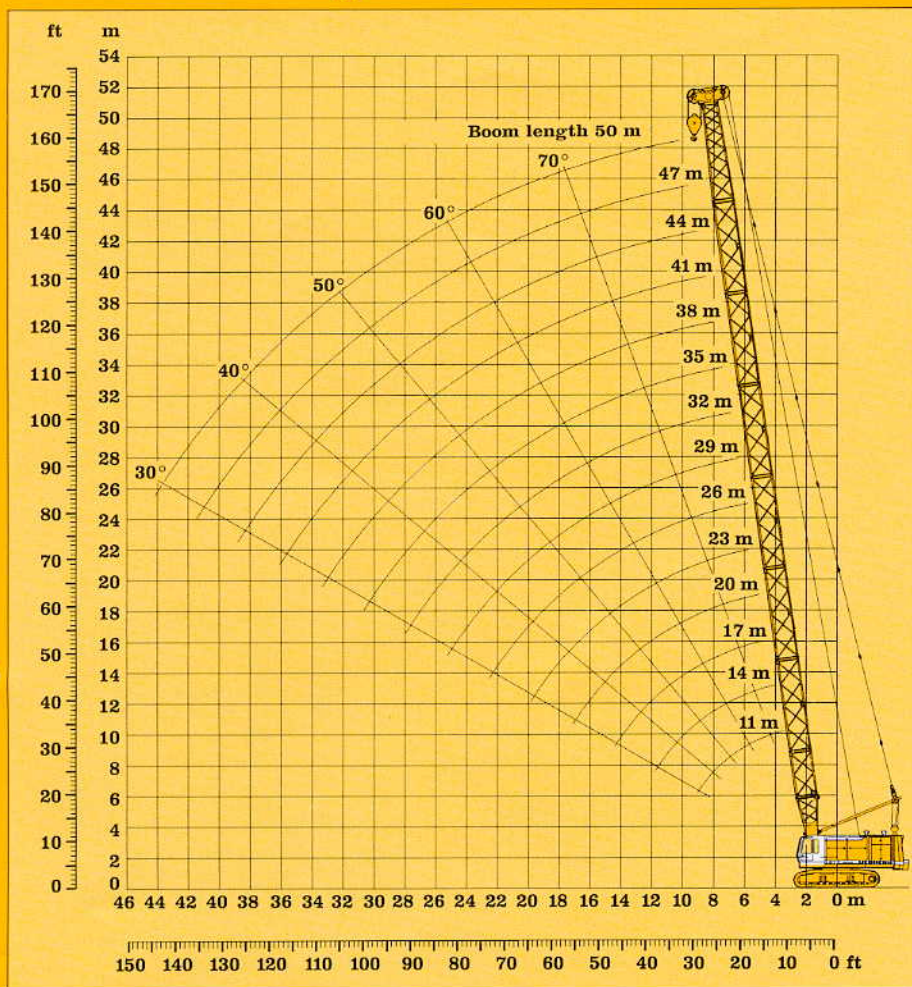

Scope of delivery:

- Basic machine with corresponding track shoes
- A-frame
- Boom foot
- Boom extension 3 m, tubular steel
- Boom extension 6 m, tubular steel
- Boom head extension 6.4 m
- Boom head
- Stay ropes according to boom length
- Main winches according to specification
- Corresponding hook block
- Load moment limiter

Remarks:

1. The lifting capacities with multi sheave boom head are valid for wide track.
2. The lifting capacities stated do not exceed 75 % of the tipping load.
3. The lifting capacities are indicated in metric tons with unlimited swing (360 degrees).
4. The weight of the lifting device must be deducted to arrive at the net load lifting capacity.
5. Working radii are measured from center of swing.
6. Machine standing on firm, level and uniform ground.
7. Max. loads without windload.

Radius m	Boom length m													
	11	14	17	20	23	26	29	32	35	38	41	44	47	50
4	90.0													
4.5	80.0	71.3												
5	71.8	68.6	64.2											
5.5	61.1	64.1	61.0	58.2										
6	53.1	53.0	53.0	52.9	52.7									
6.5	46.8	46.8	46.7	46.6	46.5	46.4								
7	41.9	41.9	41.8	41.6	41.5	41.4	41.2	40.5						
7.5	37.8	37.8	37.7	37.6	37.4	37.3	37.1	37.0	36.8					
8	34.4	34.4	34.3	34.2	34.0	33.9	33.7	33.6	33.4	33.2				
9	29.1	29.1	29.0	28.9	28.7	28.6	28.4	28.2	28.0	27.8	27.7	20.6		
10	25.1	25.1	25.0	24.9	24.7	24.6	24.4	24.2	24.0	23.8	23.6	19.0	15.1	12.2
11	22.0	22.0	21.9	21.8	21.6	21.5	21.3	21.1	20.9	20.7	20.5	17.5	13.9	11.2
12	19.4	19.5	19.4	19.3	19.2	19.0	18.8	18.6	18.4	18.2	18.0	16.2	12.8	10.4
13		17.5	17.4	17.3	17.1	16.9	16.8	16.6	16.4	16.2	16.0	15.0	12.0	9.6
14		15.8	15.7	15.6	15.4	15.3	15.1	14.9	14.7	14.5	14.3	13.9	11.2	8.9
15		14.3	14.3	14.2	14.0	13.8	13.6	13.4	13.2	13.0	12.8	12.6	10.4	8.2
16			13.0	12.9	12.8	12.6	12.4	12.2	12.0	11.8	11.6	11.4	9.7	7.6
17			11.9	11.9	11.7	11.5	11.3	11.1	10.9	10.7	10.5	10.3	9.1	7.1
18			11.0	10.9	10.8	10.6	10.4	10.2	10.0	9.8	9.6	9.4	8.5	6.6
19				10.1	9.9	9.8	9.6	9.4	9.2	9.0	8.8	8.6	8.0	6.1
20				9.3	9.2	9.0	8.9	8.7	8.5	8.2	8.0	7.8	7.5	5.7
22					7.9	7.8	7.6	7.4	7.2	7.0	6.8	6.6	6.3	4.9
24					6.9	6.7	6.6	6.4	6.2	6.0	5.7	5.5	5.2	4.2
26						5.9	5.7	5.5	5.3	5.1	4.8	4.6	4.3	3.6
28							5.0	4.8	4.5	4.3	4.0	3.8	3.5	3.0
30							4.2	4.1	3.8	3.6	3.4	3.1	2.9	2.5
32								3.5	3.3	3.0	2.8	2.5	2.3	2.0
34									2.7	2.5	2.3	2.0	1.8	1.5
36										2.1	1.8	1.6	1.3	1.1
38											1.4	1.2	0.9	0.7

Lifting capacity with multi sheave HD boom head

19.6 mt counterweight + 4.5 mt add. counterweight

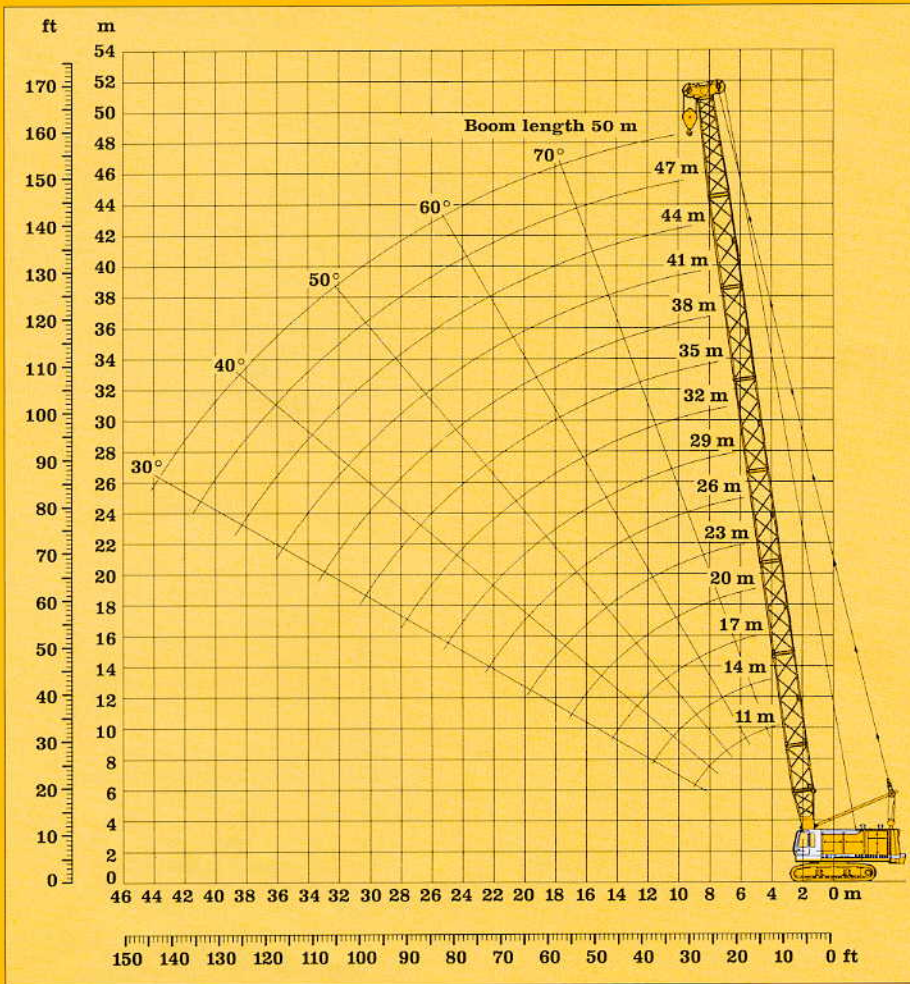

Scope of delivery:

- Basic machine with corresponding track shoes
- Add. counterweight of 4.5 mt
- A-frame
- Boom foot
- Boom extension 3 m, tubular steel
- Boom extension 6 m, tubular steel
- Boom head extension 6.4 m.
- Boom head
- Stay ropes according to boom length
- Main winches according to specs
- Corresponding hook block
- Load moment limiter

Remarks:

1. The lifting capacities with multi sheave boom head are valid for wide track.
2. The lifting capacities stated do not exceed 75 % of the tipping load.
3. The lifting capacities are indicated in metric tons with unlimited swing (360 degrees).
4. The weight of the lifting device must be deducted to arrive at the net load lifting capacity.
5. Working radii are measured from center of swing.
6. Machine standing on firm, level and uniform ground.
7. Max. loads without windload.

Radius m	Boom length m													
	11	14	17	20	23	26	29	32	35	38	41	44	47	50
4	90.0													
4.5	80.0	71.3												
5	73.6	68.2	64.2											
5.5	68.1	66.2	62.0	58.2										
6	59.2	59.2	59.1	56.3	52.9									
6.5	52.3	52.3	52.2	52.1	51.3	46.9								
7	46.8	46.8	46.7	46.6	46.4	45.6	43.0	40.5						
7.5	42.3	42.3	42.2	42.0	41.9	41.7	41.6	39.4	37.1					
8	38.5	38.5	38.4	38.3	38.1	38.0	37.8	37.6	36.2	34.1				
9	32.6	32.6	32.5	32.4	32.2	32.1	31.9	31.7	31.5	31.3	28.4	20.6		
10	28.2	28.2	28.1	27.9	27.8	27.6	27.4	27.3	27.1	26.9	23.6	19.0	15.1	12.2
11	24.7	24.7	24.6	24.5	24.3	24.2	24.0	23.8	23.6	23.4	21.9	17.5	13.9	11.2
12	21.9	22.0	21.9	21.8	21.6	21.4	21.2	21.1	20.9	20.7	20.4	16.2	12.8	10.4
13		19.7	19.6	19.5	19.3	19.2	19.0	18.8	18.6	18.4	18.2	15.0	12.0	9.6
14		17.8	17.8	17.6	17.5	17.3	17.1	16.9	16.7	16.5	16.3	13.9	11.2	8.9
15		16.1	16.2	16.0	15.9	15.7	15.5	15.3	15.1	14.9	14.7	13.0	10.4	8.2
16			14.8	14.7	14.5	14.3	14.2	14.0	13.8	13.6	13.3	12.2	9.7	7.6
17			13.6	13.5	13.3	13.2	13.0	12.8	12.6	12.4	12.2	11.5	9.1	7.1
18			12.5	12.4	12.3	12.1	11.9	11.7	11.5	11.3	11.1	10.8	8.5	6.6
19				11.5	11.4	11.2	11.0	10.8	10.6	10.4	10.2	10.0	8.0	6.1
20				10.7	10.6	10.4	10.2	10.0	9.8	9.6	9.4	9.2	7.5	5.7
22					9.2	9.0	8.8	8.6	8.4	8.2	8.0	7.8	6.6	4.9
24					8.0	7.9	7.7	7.5	7.3	7.1	6.9	6.7	5.8	4.2
26						6.9	6.7	6.5	6.3	6.1	5.9	5.6	5.1	3.6
28							5.9	5.7	5.5	5.3	5.0	4.8	4.5	3.0
30							5.1	5.0	4.8	4.5	4.3	4.0	3.8	2.5
32								4.3	4.1	3.9	3.7	3.4	3.1	2.1
34									3.6	3.3	3.1	2.8	2.6	1.7
36										2.8	2.6	2.3	2.1	1.3
38											2.1	1.9	1.6	1.0
40												1.7	1.5	0.7