

IHI

# General-Purpose Compact Telescopic Crane



*Lifting capacity 4.9 metric tons*

# PICK ACE

CCH50T

*Lifts and carries up to 3 metric tons  
Full 360 degree turning on 4 m roads  
The lowest center-of-gravity height*

IHI Construction Machinery Limited

# PICK ACE

# CCH50T

## General dimensions (Unit:mm)

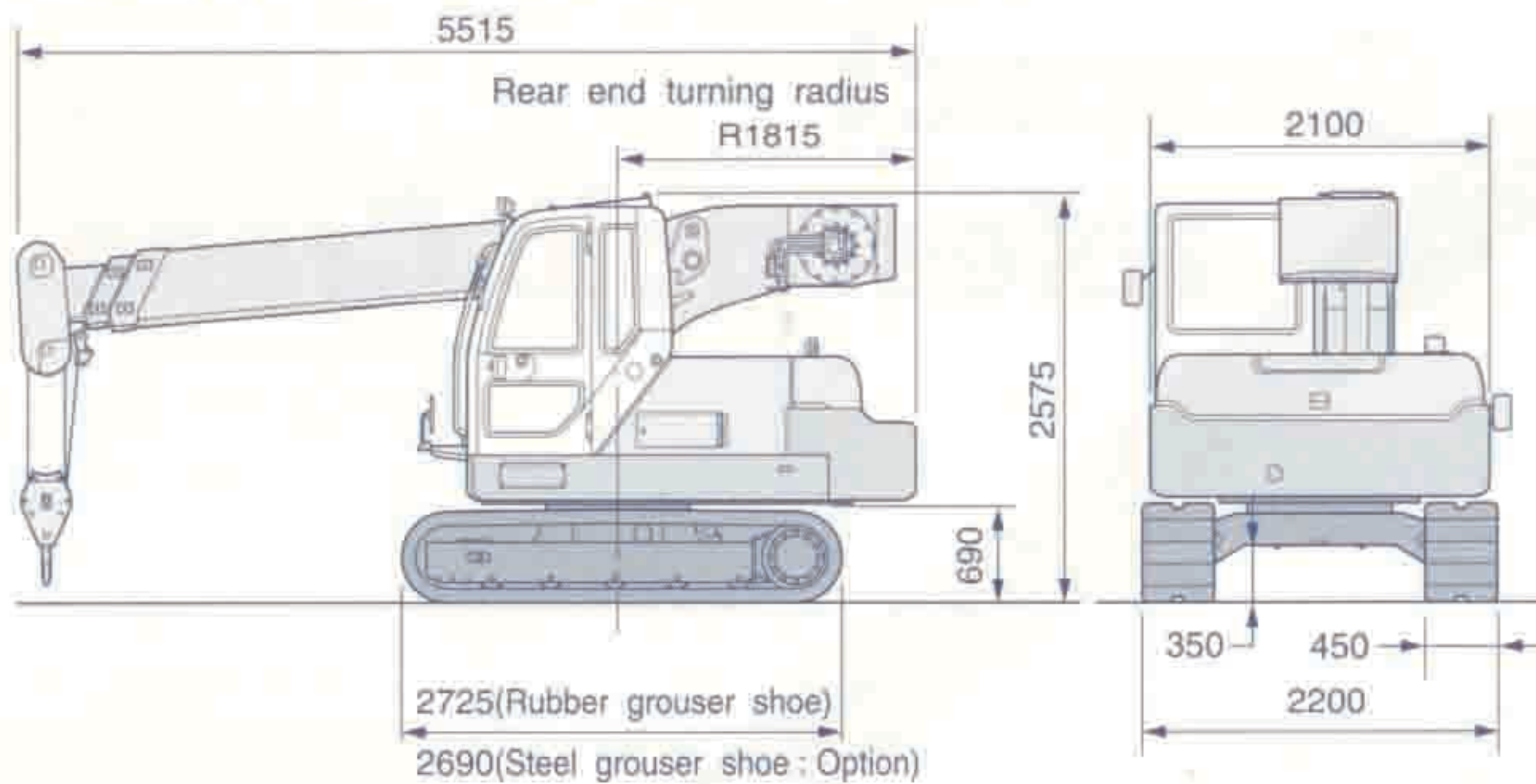

## Specifications

Performance	
Maximum lifting capacity	4.9ton X 2m
Metric ton x working radius	4.9ton X 2m
Hook block total lift	
(120m wire rope length) 4 part line	25m
2 part line	30m
Rope speed, hoist and lowering 3rd layer	56m/min
Boom hoist speed -5°-80°	18sec
Boom extension speed 4m-8.6m	15sec
Swing speed	2.4rpm
Travel speed	Hi 4.7km/hr Lo 2.8km/hr
Total operating weight w/4-8.6m boom	8200kg
Average ground bearing pressure	0.42kgf/cm <sup>2</sup>
Engine	
Model	ISUZU 4JB1 Diesel engine
Rated output	40.4kW/2150rpm 55ps/2150rpm
Maximum torque	19kgf-m/1800rpm
Fuel tank capacity	75lit

## Working range and Rated lifting loads (4-8.6m 3 Stage boom)

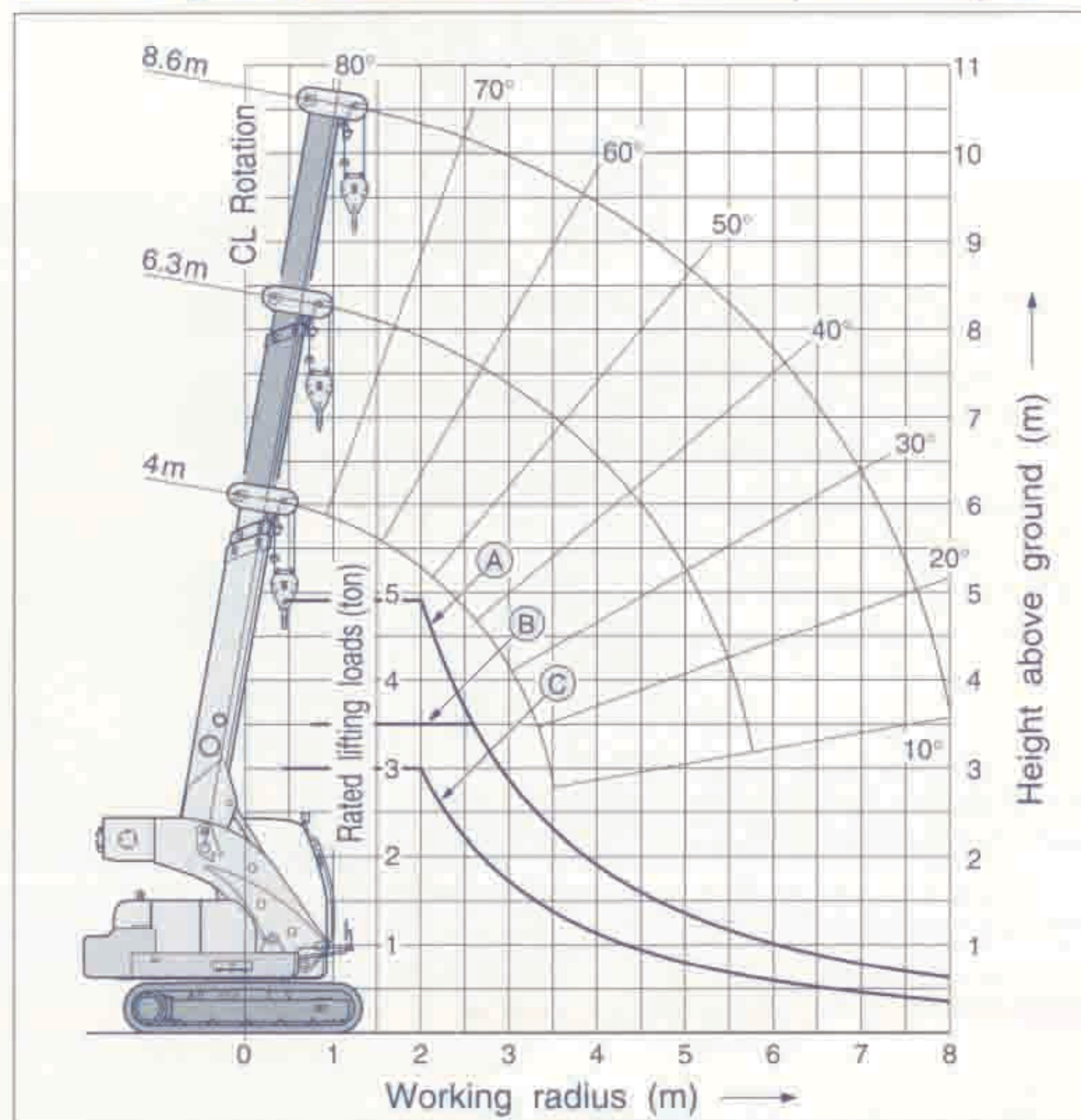

## Rated lifting loads

(Standard specifications, throughout 360°) (Unit:kg)

Working radius (m)	Stationary		Lift and carry
	(A) Boom length 4-6.3m	(B) Boom length 6.3-8.6m	(C) Boom length 4-8.6m
2.0	4900	3500	3000
2.2	4350	3500	2660
2.5	3700	3500	2230
2.6	3500	3500	2110
3.0	2870	2870	1720
3.5	2300	2300	1370
4.0	1890	1890	1130
4.5	1580	1580	940
5.0	1350	1350	810
5.5	1160	1160	690
6.0		1010	600
6.5		890	520
7.0		790	470
7.5		700	420
8.0		630	370

### Notes

- Above rated loads are based on firm level ground, within 78% of tipping load at any point 360° throughout and with front stability of 1.15 or more.
- The weight of the hook block and other lifting devices must be considered to be part of the load.  
4.9 ton hook block ..... 80Kg
- Rated lifting loads for carrying operation are based on operation firm and level surface after load has been lifted from the ground on fixed operation.  
In carrying operation, keep load close to ground and do not allow swinging. No abrupt, stop or spin turn should be allowed while carrying loads.
- Do not raise or lower, or extend or retract boom while carrying loads.
- Depending on the number of part lines, rated lifting load is limited as follows:  
2 part line ..... up to 2.5 ton  
4 part line ..... up to 4.9 ton
- Hoist wire rope specification and guaranteed breaking strength.  
10 mm dia. - 6 X Fi(29)IWRC Grade B 67.7N (6.90tf)  
or  
10 mm dia. - 6 X Fi(29)IWRC Grade A 63.6N (6.49tf)
- Maximum working radius decided by boom angle 10 degree on each boom length.